

DATE :	Jan/06/17'
CMS P/N :	A08425
Dwg NO. :	A1
CUST. P/N :	1648
CUSTOMER :	Unibrain S.A.
DESCRIPTION	1394C-9AS-9AS-2M With Ferrite
APPROVE:	

REV.	DATE	DESCRIPTION	BY
1.0	Jan/06/17'	D3614	Lina

## ■ CONFIGURATION

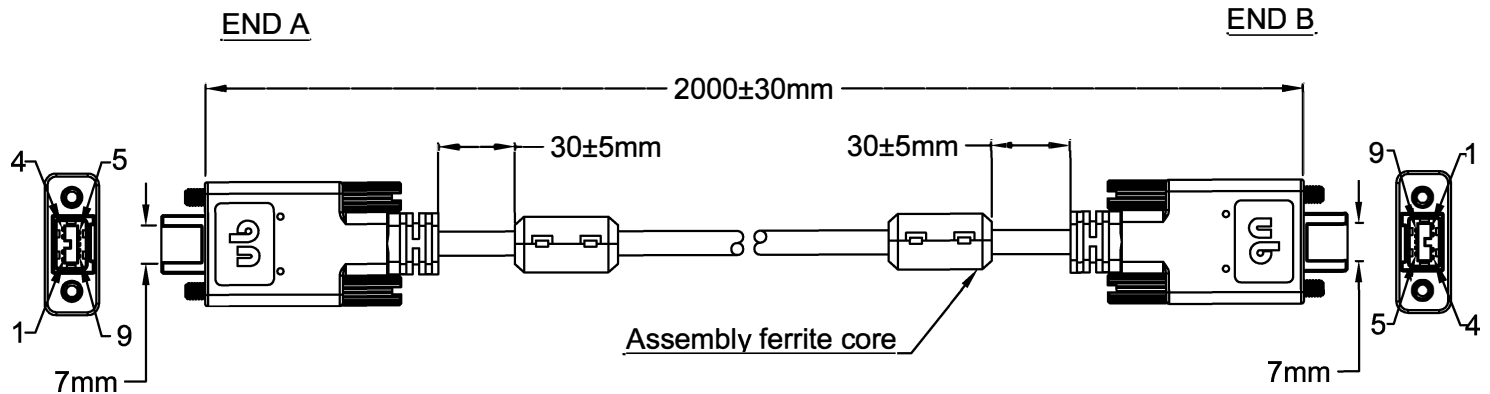

## ■ SPECIFICATION OF MATERIAL

### 1. END A

CONT. PLATING	Gold 30u"	MOLD No.	CMS-1394b10	SHIELD'G	-
CONNECTOR TYPE	HSP-AM013400			T. SCREW	Jack Screw M3x0.5 Size: 5.0x37.0x7.0mm

### 2. END B

CONT. PLATING	Gold 30u"	MOLD No.	CMS-1394b10	SHIELD'G	-
CONNECTOR TYPE	HSP-AM013400			T. SCREW	Jack Screw M3x0.5 Size: 5.0x37.0x7.0mm

### 3. WIRES

WIRE GAUGE	22Awg & 25Awg	LENGTH	2000+20-0mm	SHIELD'G	MAB
CONDUCTORS	2C+(1TP+MAE)x2	COLOR	Gray(Cool Gray 7C)	UL/CSA	UL20379
JACKET MAT'L	PVC	INS. MAT'L	SR PVC&FM-PE	WIRE O.D.	7.0mm

### 4. CONNECTOR PIN OUT

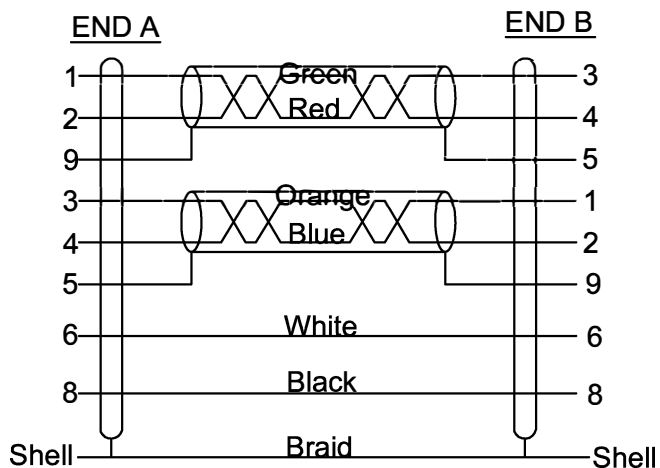

### 5. SPECIAL REQUIREMENTS

- 5.1 Product requirement for Green environment protection:RoHS.
- 5.2 Overmold PVC 65P, Black (RoHS).
- 5.3 Assembly ferrite core:35.5x18.5x19.5x8mm

