

DATE :	Jan/06/17'
CMS P/N :	B0107163
Dwg NO. :	A08426
CUST. P/N :	1647
CUSTOMER :	Unibrain S.A.
DESCRIPTION	1394C-9AS-9AS-1M With Ferrite
APPROVE:	

REV.	DATE	DESCRIPTION	BY
1.0	Jan/06/17'	D3615	Lina

CONFIGURATION

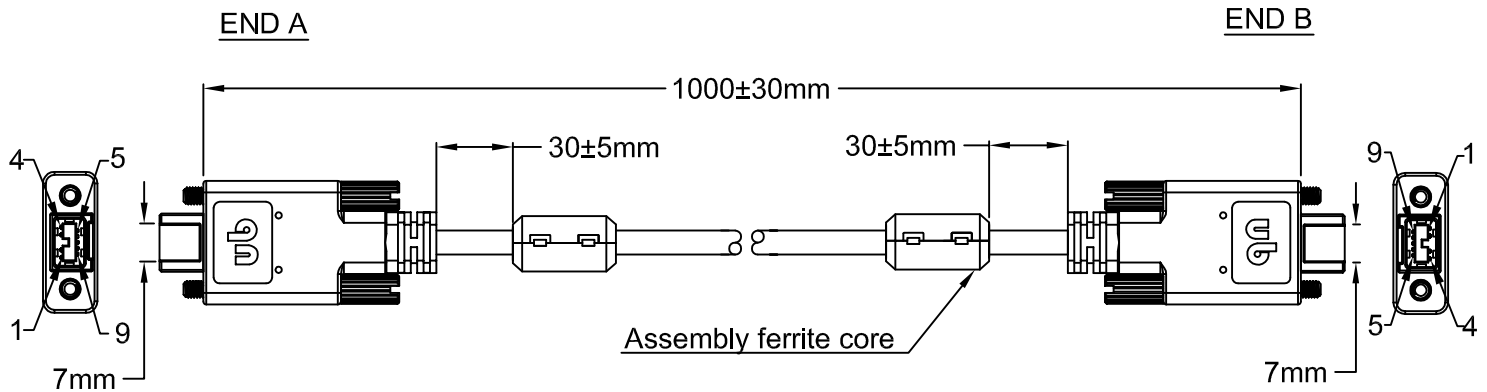

SPECIFICATION OF MATERIAL

1. END A

CONT. PLATING	Gold 30u"	MOLD No.	CMS-1394b10	SHIELD'G	-
CONNECTOR TYPE	HSP-AM013400			T. SCREW	Jack Screw M3x0.5 Size: 5.0x37.0x7.0mm

2. END B

CONT. PLATING	Gold 30u"	MOLD No.	CMS-1394b10	SHIELD'G	-
CONNECTOR TYPE	HSP-AM013400			T. SCREW	Jack Screw M3x0.5 Size: 5.0x37.0x7.0mm

3. WIRES

WIRE GAUGE	22Awg & 25Awg	LENGTH	1000+20-0mm	SHIELD'G	MAB
CONDUCTORS	2C+(1TP+MAE)x2	COLOR	Gray(Cool Gray 7C)	UL/CSA	UL20379
JACKET MAT'L	PVC	INS. MAT'L	SR PVC&FM-PE	WIRE O.D.	7.0mm

4. CONNECTOR PIN OUT

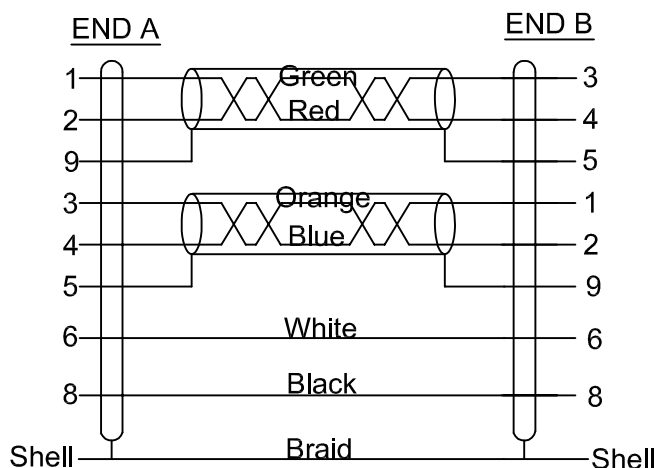

5. SPECIAL REQUIREMENTS

- Product requirement for Green environment protection:RoHS.
- Overmold PVC 65P, Black (RoHS).
- Assembly ferrite core:35.5x18.5x19.5x8mm

