

USB 3.1, Gen.2 (10 Gbps) USB-C to USB-C cable with eMarker, length: 75cm/100cm

REV	DATE	DESCRIPTION
1.1	April, 27, 2018	R-2675

Mechanical Drawing

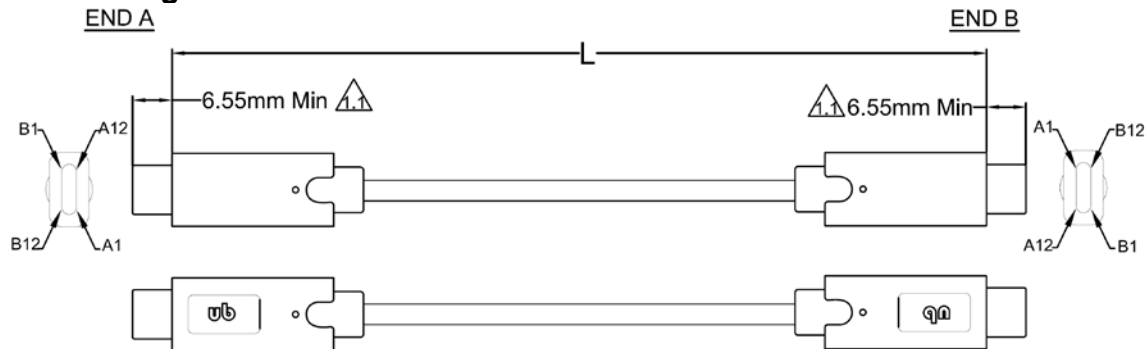

Specification of Material

1. End A

CONT. PLATING

CONNECTOR TYPE

2. End B

CONT. PLATING MOLD No.

CONNECTOR TYPE

3. Wires

WIRE GAUGE

LENGTH

SHIELD'G

CONDUCTORS

COLOR

UL/CSA

JACKET MAT'L

INS. MAT'L

WIRE OD

4. Connector Pinout

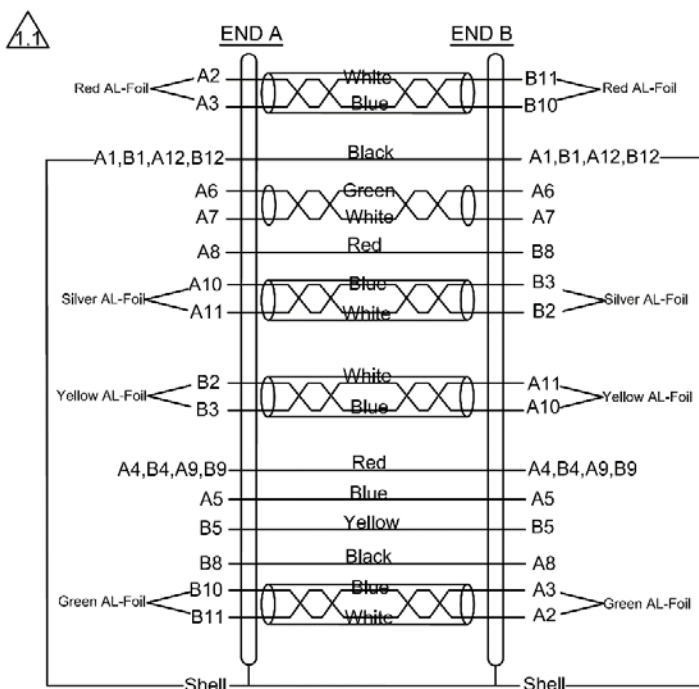

Special Requirements

5.1 Product requirement for Green environment protection: RoHS & Reach compliance.

5.2 Overmold PVC is 45P Ferrari Red 1795C.

5.3 Label on right up corner in the front side of master carton.

5.4 Length table:

P/N	LINE LENGTH L	CUT LENGTH L1
1843	750±30mm	765+15-0mm
1844	1000±30mm	1015+15-0mm