

|             |  |
|-------------|--|
| DATE :      | Aug/05/14'                             |
| CMS P/N :   | B0106772                               |
| Dwg NO. :   | A07634                                 |
| CUST. P/N : | 1641                                   |
| CUSTOMER :  | Unibrain, Inc. (North & South America) |
| DESCRIPTION | 1394C-9AS-9AS-450-00 with Ferrite      |
| APPROVE:    |  |

| REV. | DATE       | DESCRIPTION | EY |
|------|------------|-------------|----|
| 1.0  | Aug/05/14' | D3065       | -  |
|      |            |             |    |
|      |            |             |    |

**CONFIGURATION**

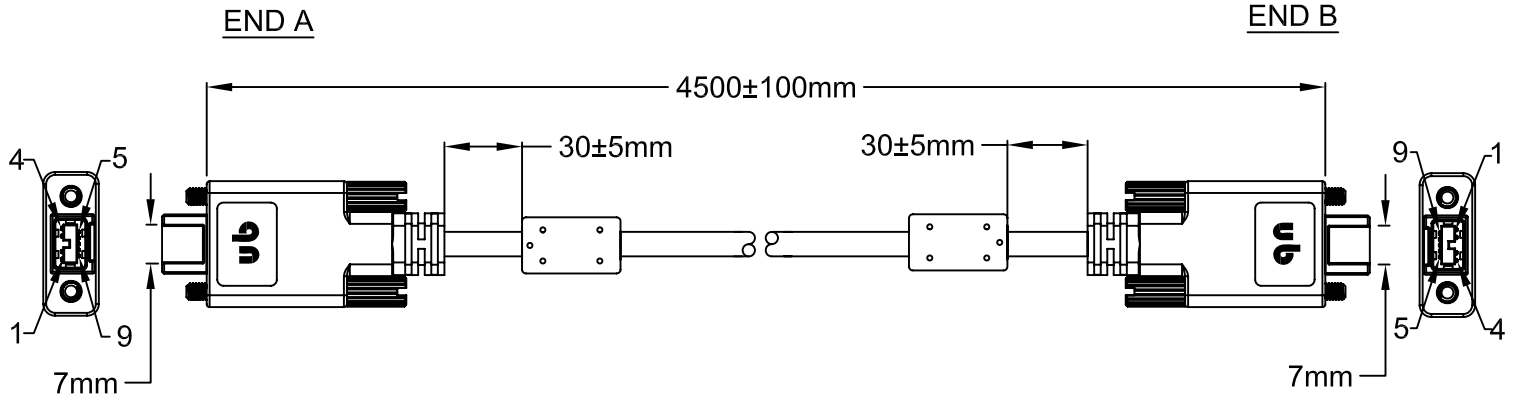

**SPECIFICATION OF MATERIAL**

**1. END A**

|                |              |          |             |          |   |
|----------------|--------------|----------|-------------|----------|---|
| CONT. PLATING  | Gold 30u"    | MOLD No. | CMS-1394b10 | SHIELD'G | -   |
| CONNECTOR TYPE | HSP-AM013400 |          |             | T. SCREW | Jack Screw M3x0.5<br>Size: 5.0x37.0x7.0mm |

**2. END B**

|                |              |          |             |          |   |
|----------------|--------------|----------|-------------|----------|---|
| CONT. PLATING  | Gold 30u"    | MOLD No. | CMS-1394b10 | SHIELD'G | -   |
| CONNECTOR TYPE | HSP-AM013400 |          |             | T. SCREW | Jack Screw M3x0.5<br>Size: 5.0x37.0x7.0mm |

**3. WIRES**

|              |                |            |                    |           |         |
|--------------|----------------|------------|--------------------|-----------|---------|
| WIRE GAUGE   | 22Awg & 25Awg  | LENGTH     | 4500+50-0mm        | SHIELD'G  | MAB     |
| CONDUCTORS   | 2C+(1TP+MAE)x2 | COLOR      | Gray(Cool Gray 7C) | UL/CSA    | UL20379 |
| JACKET MAT'L | PVC            | INS. MAT'L | SR PVC&FM-PE       | WIRE O.D. | 7.0mm   |

**4. CONNECTOR PIN OUT**

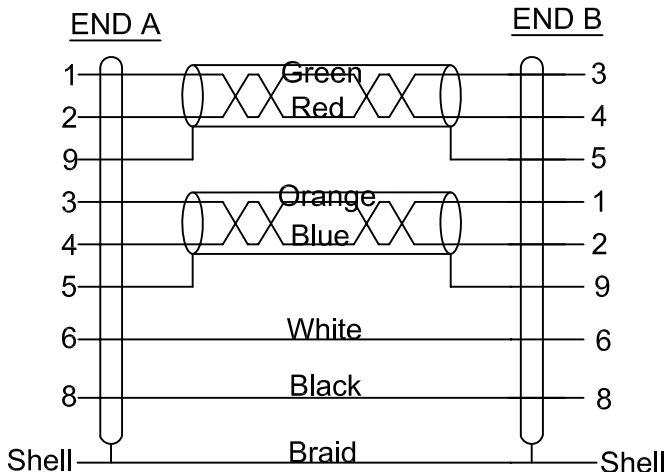

**5. SPECIAL REQUIREMENTS**

- 5.1 Product requirement for Green environment protection:RoHS.
- 5.2 Overmold PVC 65P, Black (RoHS).
- 5.3 Ferrite Bead is :RH17.5x28.5x9.5mm
- 5.4 FB mold No.: CMS-FB01
- 5.5 Ferrite Bead PVC Overmold is 65P Black (RoHS).
- 5.6 The high frequency test of the product is not guaranteed.